

WORKLAB

Perforated metal sheet back panel

Metal frame

Desktop

Lower cabinet

Footrest metal beam

Fabric back panel

Shelves

Metal lower bases

Castors



Technical information

Configurations

- Mobile shelving unit with 4 fixed shelves and semi-open back (1)
- Mobile shelving unit with 2 fixed shelves, cabinet and semi-open back (2)
- Mobile shelving unit with 2 fixed shelves, cabinet and back panel (3)
- Mobile media wall with fixed shelf, cabinet and back panel (4)
- Mobile workstation with fixed cabinet and back panel (5)

1



2



3



4



5



Metal frame

- Welded metal tube – 25x25 mm;
- Powder coated metal.

Metal lower bases

- Metal tube – 50x25 mm;
- In all configurations the length is 590 mm, except for workstation with a desktop – the length is 650 mm;
- Powder coated metal.

Footrest metal beam

- Only in the workstation configuration;
- Metal tube – Ø30 mm;
- Powder coated metal (double painting).

Castors

- Four swivel castors, Ø100 mm;
- With wheel brakes;
- Rotates in all directions;
- Load capacity - 100 kg per castor;
- Make sure that before relocating a unit with castors, all electrical components are disconnected from the main power source and hanged on hook of the side panel or placed securely.

Shelves

- 25 mm MFC (melamine) with 2 mm ABS edging;
- Load capacity – 25 kg.

Lower cabinet

- Top, bottom, side and back panels are made of 25 mm MFC (melamine) with 2 mm ABS edging;
- Sliding doors are made of 16 mm MFC (melamine) with 1 mm ABS edging;
- Dimensions: 280x566, H=370 mm (inner, two sections).

Desktop

- Only in the workstation configuration, order separately;
- 25 mm MFC (melamine) with 2 mm ABS edging;
- The corners of desktop are rounded – R80 mm;
- Scallop for cable management: 350x40 mm;
- Optional cut-out for a power socket integration.

Fabric back panel

- Made of 16 mm chipboard;
- Covered with 3 mm foam;
- Upholstered with fabric.

Fabric and whiteboard back panel

- Fabric side is made of 8 mm MDF covered with 3 mm foam;
- Upholstered with fabric;
- Whiteboard side is made of 12 mm chipboard pressed in HPL with 1 mm ABS edging.

Perforated metal sheet back panel

- Perforated 1 mm metal sheet with a Ø8 mm hole;
- The back panel has three vertical sections with a bended central part (except a shelving unit configuration);
- Top and bottom welded with metal tube 20x20mm;
- The edges are welded with metal profile;
- Matches the colour of the frame;
- Powder coated metal.

Accessories (optional)

Fabric side panel (1, 2)

- With or without a metal hook for wire management;
- 8 mm MDF covered with 3 mm foam;
- Upholstered with fabric;
- Double-sided panel hides an inner metal construction;
- Metal brackets for mounting;
- Load capacity of metal hook - 3 kg;
- Powder coated metal.

Perforated metal sheet side panel (3, 4)

- With or without a metal hook for wire management;
- Perforated 1 mm metal sheet with a Ø8 mm hole;
- Two edges are welded with metal profile;
- Fixed with screws;
- Load capacity of metal hook - 3 kg;
- Powder coated metal.

Side shelf (5)

- Powder coated metal;
- Should be hanged only on the crossbars of the side frame;
- Fixed with screws;
- Load capacity - 10 kg per shelf.

Hook (6)

- Powder coated metal;
- Should be hanged only on the crossbars of the side frame;
- Fixed with a screw;
- Load capacity - 5 kg per hook.

Screen holder (7)

- Two types of holders: for perforated metal back and fabric back;
- Powder coated metal;
- VESA standard - 100x100 mm;
- Recommended screen weight is up to 15 kg;
- Screws for screen fixing to VESA plate are not included.

1



2



3



4

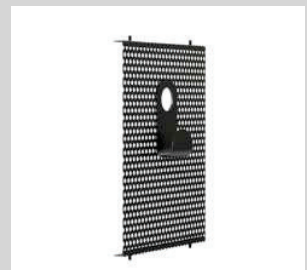

5



6



7



Range

Mobile shelving unit
with 4 fixed shelves and semi-open back

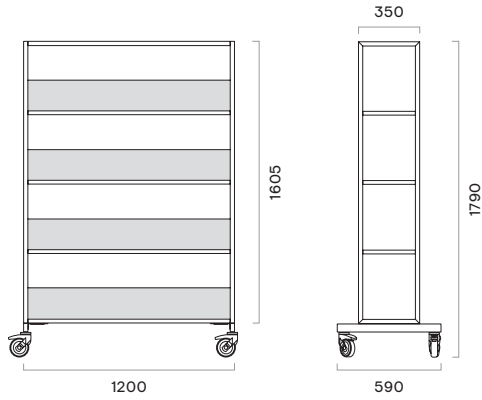

Mobile shelving unit
with 2 fixed shelves, cabinet and semi-open back

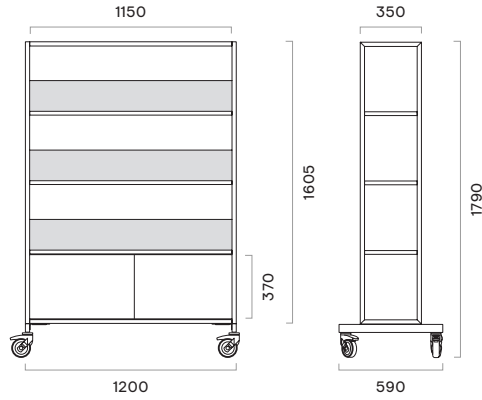

Mobile shelving unit
with 2 fixed shelves, cabinet and back panel

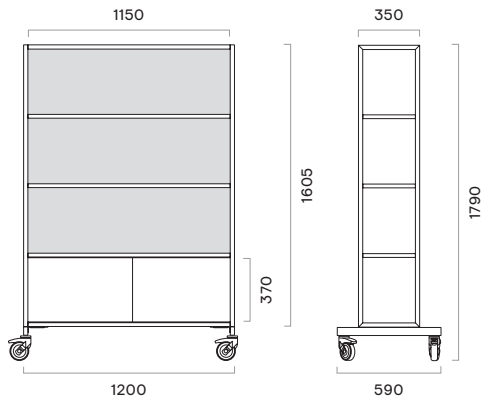

Mobile media wall
with fixed shelf, cabinet and back panel

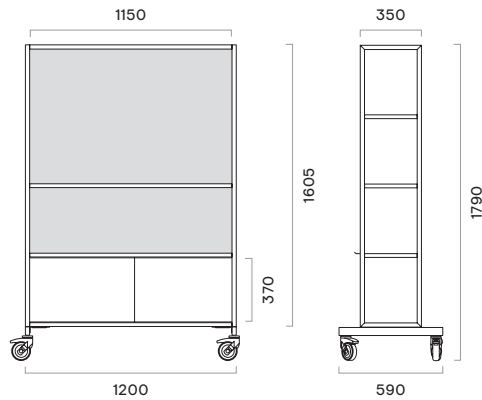

Mobile workstation
with fixed cabinet and back panel

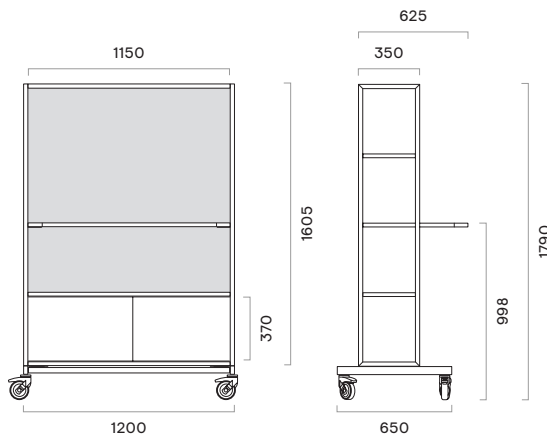

Desktop for a mobile workstation

with a scallop cut-out for wire management

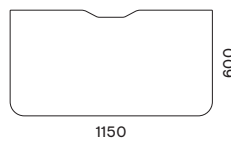

with a scallop cut-out for wire management and a cut-out for a power socket

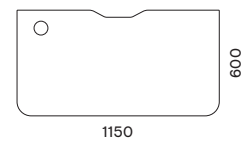

Accessories

Side panels

Perforated metal

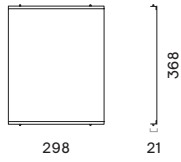

Fabric

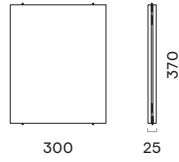

Side panel with a hook for wire management

Perforated metal

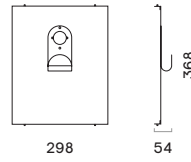

Fabric

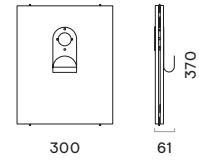

Side shelf



Hook

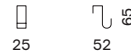

Screen holder

For the back side of perforated metal

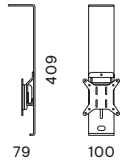

For the back side of fabric/melamine

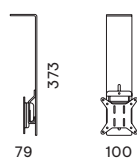

Additional information

- Only one accessory (except hook) can be fixed in the space between two crossbars of the side frame. Two hooks can be placed on one crossbar.

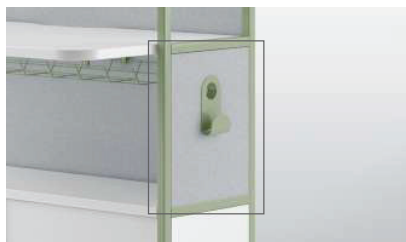

- There are two mounting options for the screen: on the front side or on the back side.

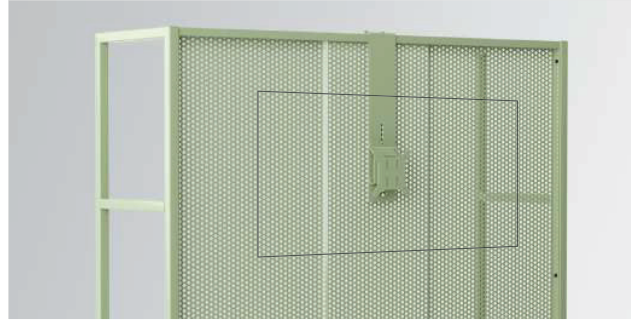
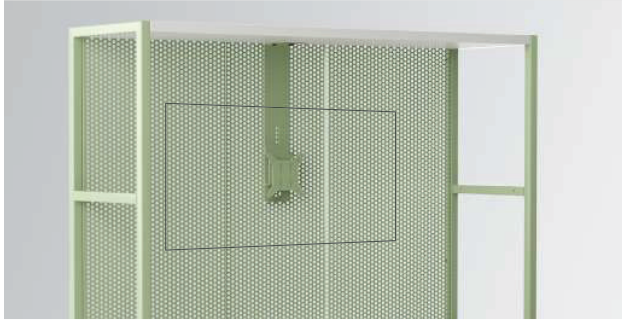

- Convenient electrical solutions for wire management. See the example below.



Ordering example

ZWL126	-	D1	T1	-	ZE1
Product		Shelves and cabinet	Metal frame and panel		Pattern

Description	W	D	H	Code	Price, GBP (RRP)					
-------------	---	---	---	------	------------------	--	--	--	--	--

Melamine:

M1 D2 D1 N3 N1 | D5 D3 N2 D4 J4

Metal: E A M T1 S1 ME1 ME2



Mobile shelving unit with 4 fixed shelves and semi-open back.

1200

590
(350)*

1790

ZWL121

924

1028



Mobile shelving unit with 2 fixed shelves, cabinet and semi-open back.

1200

590
(350)*

1790

ZWL122

1088

1208

Fabric:

Berta
Bondai
Era

Lucia

Synergy
Velitopresto
Step/Step
melange

Melamine:

M1 D2 D5 D3 M1 D2 D5 D3 M1 D2 D5 D3
D1 N3 N2 D4 D1 N3 N2 D4 D1 N3 N2 D4
N1 J4 N1 J4 N1 J4

Metal: E A M T1 S1 ME1 ME2

! Please note that when ordering mobile workstation configuration, desktop (ZWL111 or ZWL112) must be ordered separately.



Mobile shelving unit with 2 fixed shelves, cabinet and back panel.

1200

590
(350)*

1790

ZWL123

1244

1340

1284

1384

1468

1568



Mobile media wall with fixed shelf, cabinet and back panel.

1200

590
(350)*

1790

ZWL124

1188

1276

1228

1316

1412

1500



Mobile workstation with fixed cabinet and back panel, without desktop (desktop must be ordered).

1200

650
(350)*

1790

ZWL125

1192

1260



1240

1304

1424

1488

* Frame depth

Description	W	D	H	Code	Price, GBP (RRP)		
					M1 D2 D1 N3 N1	D5 D3 N2 D4 J4	
Melamine:							
Metal: E A M T1 S1 ME1 ME2							
Pattern type: ZE1							
	Mobile shelving unit with 2 fixed shelves, cabinet and back panel.	1200	590 (350)*	1790	ZWL126	1440	1544
	Mobile media wall with fixed shelf, cabinet and back panel.	1200	590 (350)*	1790	ZWL127	1392	1480
	Mobile workstation with fixed cabinet and back panel, without desktop (desktop must be ordered).	1200	650 (350)*	1790	ZWL128	1400	1468

Fabric:						
Berta Bondai Era		Lucia		Synergy Velitopresto Step/Step melange		
Whiteboard: H71						
Melamine:						
M1 D2 D1 N3 N1	D5 D3 N2 D4 J4	M1 D2 D1 N3 N1	D5 D3 N2 D4 J4	M1 D2 D1 N3 N1	D5 D3 N2 D4 J4	M1 D2 D1 N3 N1
Metal: E A M T1 S1 ME1 ME2						

	Mobile shelving unit with 2 fixed shelves, cabinet and whiteboard back panel.	1200	590 (350)*	1790	ZWL12A	1540	1640	1568	1668	1668	1768
	Mobile media wall with fixed shelf, cabinet and whiteboard back panel.	1200	590 (350)*	1790	ZWL12B	1484	1572	1516	1600	1612	1700
	Mobile workstation with fixed cabinet and whiteboard back panel, without desktop (desktop must be ordered).	1200	650 (350)*	1790	ZWL12C	1492	1560	1520	1588	1620	1684

* Frame depth

Description	W	D	H	Code	Price, GBP (RRP)									
					Melamine:									
					M1	D2	D1	N3	N1	D5	D3	N2	D4	J4

! Please note that when ordering desktop with a cut out for power socket, ARU703 or ARU704 must be ordered too, as a separate product.



Desktop with a scallop for wire management

1150

600

25

ZWL111

72

96



Desktop with a scallop and cut-out for power socket

1150

600

25

ZWL112

72

96

Fabric:

**Berta
Bondai
Era**

Lucia

**Synergy
Velitopresto
Step/Step
melange**



Side panel (1 pcs.)

300

25

370

ZWZ001

60

68

84

Set of side panels (2 pcs.)

300

25

370

ZWZ002

112

128

164

Set of side panels (4 pcs.)

300

25

370

ZWZ003

224

256

332

Set of side panels (6 pcs.)

300

25

370

ZWZ004

340

384

492

Set of side panels (8 pcs.)

300

25

370

ZWZ015

456

512

660

Fabric:

**Berta
Bondai
Era**

Lucia

**Synergy
Velitopresto
Step/Step
melange**

Metal: **E A M T1 S1 ME1 ME2**



Side panel with a hook for wire management (1 pcs.)

300

61

370

ZWZ005

76

84

100

Metal: **E A M T1 S1 ME1 ME2**

Pattern type: **ZE1**



Side panel (1 pcs.)

298

21

368

ZWZ006

56

Set of side panels (2 pcs.)

298

21

368

ZWZ007

104

Set of side panels (4 pcs.)

298

21

368

ZWZ008

212

Set of side panels (6 pcs.)

298

21

368

ZWZ009

316

Set of side panels (8 pcs.)

298

21

368

ZWZ016

424